



VENMAR®

VENMAR AVS SOLO 2.0

Part no. 45729

200 to 320 m³/h (100 Pa)



VB0091

THE "EXCESS MOISTURE" SYSTEM; WHEN ALL THE SIGNS POINT TO EXCESS HUMIDITY.

The dramatic strength of the AVS SOLO is its ability to help control humidity and window condensation during the colder season. Customers benefit from clean, fresh air in a more comfortable environment, while optimizing energy efficiency and protecting their homes.

- Reversible unit installation
- Improved standard filter performance
- Unique pan design, easy to clean and maintain
- Integrated balancing dampers and pressure taps
- Crossflow heat recovery core
- Exclusive HomeShield™ patented defrost system
- SilentSure™ operation
- PSC motor

REPAIRS AND MAINTENANCE

All parts of the AVS SOLO can be removed in less than five minutes, allowing direct access for easy repairs. The low power consumption PSC motor is permanently lubricated. Even better, the entire motor assembly can be removed in less than a minute for easier maintenance. Finally, the electronic circuit board eliminates electromechanical parts, reducing repair time to a minimum.

WARRANTY

The Venmar AVS SOLO is fully protected by a 5-year warranty and the heat recovery core is covered by a lifetime warranty.

Available at:

HEAT RECOVERY VENTILATOR

Controls

- Our brand new main control Altitude no. 40440 allows you to manage your ventilation with a new programmable mode. Also included, our unique and fully automated optimizer mode called the Smart mode. The Altitude brings your ventilation experience to new heights.
- Also, the following main control is available:
-VENTA no. 40315
- One or more of the following optional controls can be added:
Humidity Control: no. 11297
60-minute mechanical timer: no. 00910
20/40/60-minute push button: no. 03364

Options

- Complete line of registers and diffusers
- Electric duct heater
- Filters: - Charcoal no. 03315
- Pleated no. 03316
- Electronic no. 03314

Homeshield™ Defrosting System

The AVS SOLO uses a unique defrosting method. No negative pressure is created by air exhausted to the outside, as the air is recirculated into the house, thus avoiding any backdraft from the chimney. Moreover, this defrosting method by air circulation ensures that no shortage of air is created for combustion units.

| OUTSIDE TEMPERATURE °C | DEFROST CYCLE |
|------------------------|----------------------------------|
| | DEFROSTING MIN. / OPERATING MIN. |
| WARMER THAN -5 | NO DEFROST |
| -5 to -15 | 6/60 |
| -15 to -27 | 6/32 |
| -27 & less | 6/20 |

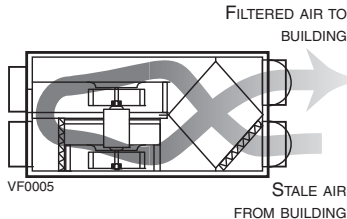

Heat Recovery Core

Dimensions: 31 cm x 36 cm x 40 cm
 Exchange surface: 9.54 m²
 Weight: 2.8 kg
 Material: Polypropylene
 Type: Crossflow core
 Warranty: Limited lifetime

Requirements and Standards

- Complies with the essential requirements of EN 60335-1 Safety of household and similar electrical appliances - Part 1: General requirements (September 1994) and Amendment A11 (May 1995).

Dimensions and Service Clearances: Venmar AVS SOLO 2.0

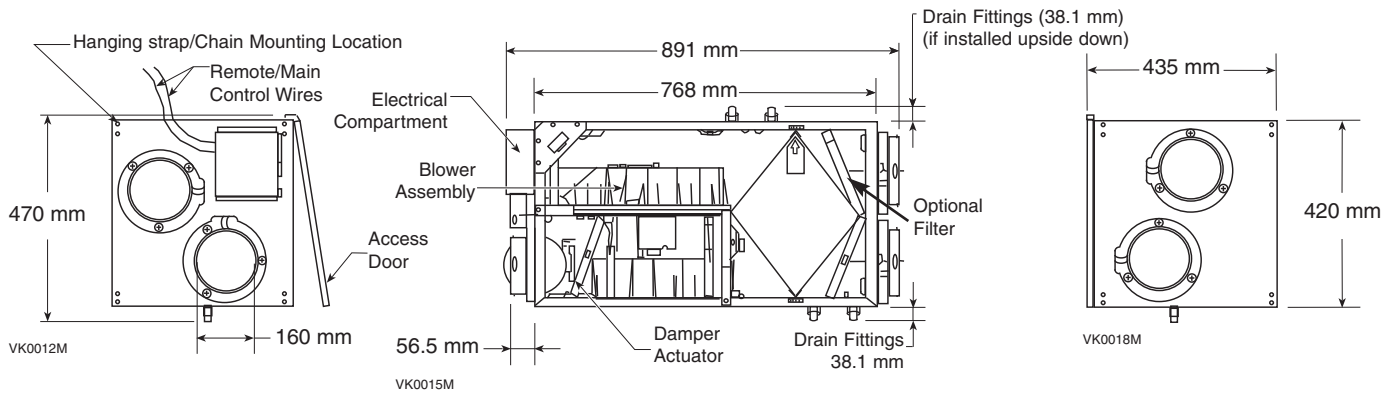

Ventilation Performance (Unit at 50 Hz)

| EXT. STATIC PRESSURE Pa | NET SUPPLY AIR FLOW m ³ /h | GROSS AIR FLOW | |
|----------------------------|--|-----------------------------|------------------------------|
| | | SUPPLY m ³ /h | EXHAUST m ³ /h |
| 25 | 392 | 396 | 392 |
| 50 | 375 | 379 | 379 |
| 75 | 358 | 362 | 366 |
| 100 | 341 | 344 | 352 |
| 125 | 324 | 327 | 338 |
| 150 | 307 | 310 | 324 |

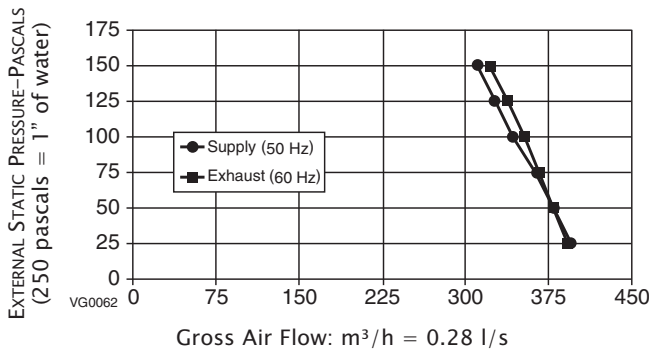

Energy Performance

| SUPPLY TEMPERATURE °C | NET AIR FLOW m ³ /h | POWER CONSUMED WATTS | SENSIBLE RECOVERY EFFICIENCY | APPARENT SENSIBLE EFFECTIVENESS | LATENT/RECOVERY MOISTURE TRANSFER |
|---------------------------|-----------------------------------|-------------------------|------------------------------|---------------------------------|-----------------------------------|
| HEATING | | | | | |
| 0 | 202 | 124 | 60 | 70 | -0.01 |
| 0 | 210 | 197 | 53 | 62 | -0.01 |
| 0 | - | - | - | - | - |
| -25 | 133 | 114 | 62 | 80 | 0.08 |
| -25 | - | - | - | - | - |
| COOLING | | | | | |
| TOTAL RECOVERY EFFICIENCY | | | | | |
| 35 | - | - | NOT TESTED | | |
| 35 | - | - | - | | |

NOTE: All specifications are subjected to change without notice.

Specifications and Ratings

- Model: Venmar AVS SOLO 2.0
- Part Number: 45729
- Total Assembled Weight (Including polypropylene core): 30.5 Kg
- Supply and Exhaust Air Duct Connections: 16 cm diameter
- Drains: 1.2 cm fittings with 3 m PVC drain
- Filters: -20 ppi washable reticulated foam 39 cm x 18 cm x 1.9 cm
- Cabinet: pre-painted steel

- Insulation: 2.54 cm aluminum foil faced fiberglass, 2.10 cm expanded polystyrene
- Mounting: Suspension by chains and springs
- Supply and Exhaust Blower Motor: 1 motor
 - Protection type: Thermally protected
 - Insulation class: B
- V (motor marking): 120V ac, 50/60 Hz, 1.7A, 1040/1300/1630 RPM

- Fan Speed Control:
 - Low or increased low & high speed
 - Two speeds available for the user
 - Low or increased low speed is selected at the time of installation
- Heat Recovery Core:
 - Heat Exchange Surface Area: 9.54 m²
 - Type/Material: Crossflow/Polypropylene
- Unit Electrical Characteristics:

| Volts | Freq | Amperes | Watts | IP |
|---------|------|---------|-------|----|
| 230-240 | 50Hz | 1.0 | 188 | 20 |